

# **S SELICK**

# **STT160**



***Rugged • Adaptive • Powerful***

The STT160

Rough Terrain Tow Forklift

- Four wheel drive
- Four wheel steer

## Standard specifications

For out of the ordinary towing applications, look no further than the STT160 rough terrain tow forklift. Equipped with four wheel steer, four wheel drive and a full range of attachment capabilities, this tow forklift can adapt to handle any need. Built durable and with operator comfort in mind, the STT160 rough terrain tow forklift meets or exceeds ANSI B56.6 ROPS/FOPS standard.

## Engine

DieselMax 444, Tier III, low noise, low emission, turbocharged, intercooled, four-cylinder, 114 hp, direct injection diesel engine with fuel/water separator with hand primer, dual element air filter, maintenance free pre-cleaner & vertical exhaust.

## Transmission

6-speed fully automatic powershift transmission

## Axles

Trunnion mounted planetary axles. Internal hydraulic disc brakes, limited slip rear differential improves traction. Integral steer cylinders.

## Brake system

Enclosed multi-disc, oil-immersed service brakes with independent parking brake, spring applied, hydraulically released, axle mounted to handle loads of all sizes.

## Steering

4 wheel steering with hydraulic power assist.

## Instruments

Full instrument package includes hour meter, water in fuel gauge and air restriction monitor.

## Mast

Slider style, no bearing mast design minimizes need for adjustment and maintenance.

90° hitch access with excellent visibility, sliding pin hookup and 3" pintle hitch.

Control handles provide lift and locking pintle functions.

## Optional equipment

- Turn signals
- Block heater
- Cab w/lockable doors & tinted windows
- AM/FM MP3 player
- Air conditioning
- Outside rear-view mirrors
- Variety of forks and attachments

# STT160

## rough terrain tow forklift

Lift capacity of 20,000 lbs @ 8" load centre

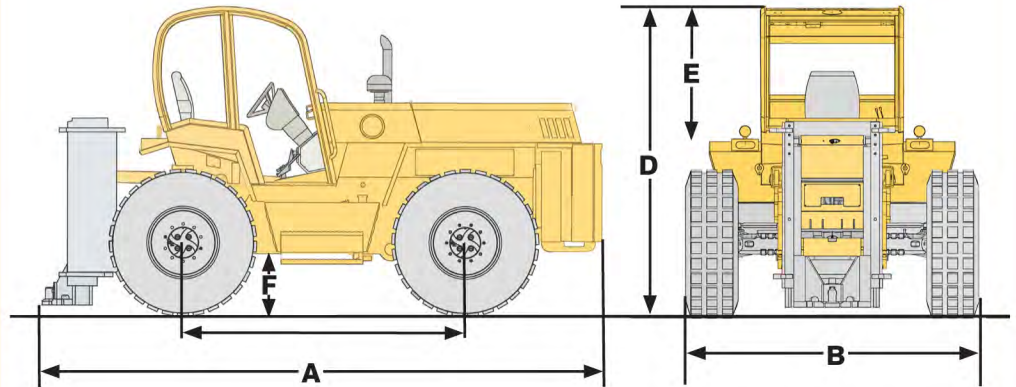

Model	Ref	STT160
Lift capacities @ 8 inch load centre		20 000 lbs/9 072 kg
Total weight (w/slider mast)		22,670 lbs/10,283 kg
Drawbar (laden)		19 800 lbs/8 981 kg
Overall length (to end of mast)	A	205"/4 699 mm
Overall width	B	100"/2 540 mm
Wheelbase	C	100"/2 540 mm
Height to top of overhead guard	D	106"/2 692 mm
Distance from seat to overhead guard	E	43"/1 092 mm
Outside turning radius		189"/4,801 mm
Frame underclearance	F	21"/533 mm
Axle(s)		Dana 213 Series
Travel speed (standard)		16 mph
Gradeability		25%
Tire size type & size		Front/Rear (pneumatic) 15.5 x 25 - 16 ply L3
Electrical System		Alternator - 95A; Battery 1 000 CCA (12 volt system)
Engine model		Dieselmax 444 Series intercooled turbocharged, Tier III
Cylinders		4
Engine output (gross power)		114 hp @ 2 200 rpm
Peak torque		325 ft-lbs @ 1 300 rpm
Transmission manufacturer & type		Dana T20000 Automatic Powershift

*Because of our constant dedication to product improvement, all specifications are subject to change without notice.*



**Sellick Equipment Limited**  
P.O. Box 1000/358 Erie Street North  
Harrow, Ontario, Canada • N0R 1G0  
519-738-2255 • sellick@mnsi.net  
www.sellickequipment.com



Sold and serviced by: